

B999 M

1500 ML CARTRIDGE DISPENSER

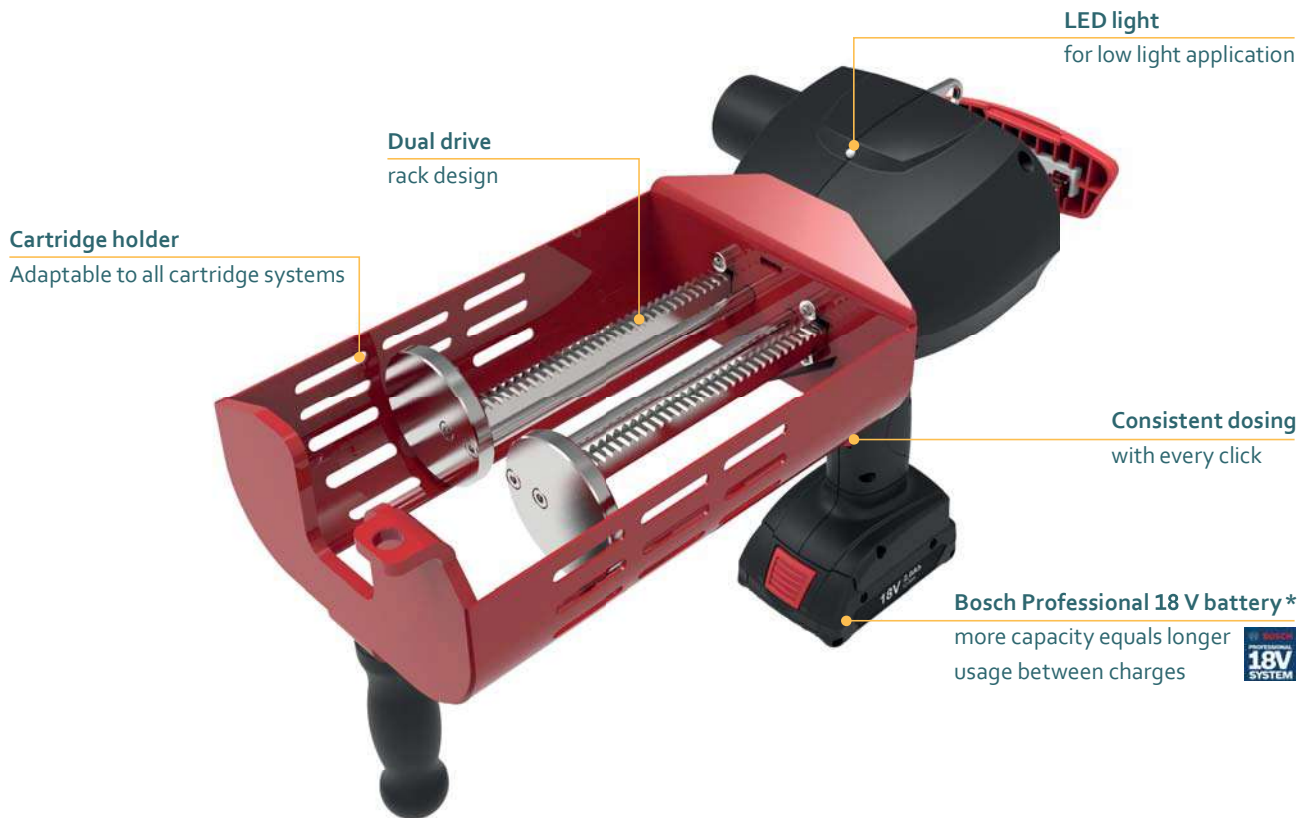

Model shown: B999 M 1500 mL

FEATURES

- Unique memory function
- Dual drive rack design
- Anti-drip function
- 18 V Li-ion high performance battery
- U-opening with cartridge snap fit
- Customization possible

BENEFITS

- Consistent dosing with every click
- Reproduces quality of each adhesive
- Clean and efficient working
- Charge time: 65 min (100%)
- For easy insertion and removal of cartridges
- Customer labelling

APPLICATIONS



PRODUCT BY RANGE



B999 M

THE B999 M 2-COMPONENT BATTERY DISPENSER DUAL DRIVE RACK AND UNIQUE MEMORY FUNCTION REPRODUCES CONSISTENT DOSING EVERY TIME. ACCIDENTAL MATERIAL DISCHARGE IS PREVENTED WITH THE BUILT-IN ANTI-DRIP MECHANISM.

SPECIFICATIONS

- Weight: 4.2 kg / 7.9 lbs
- Cartridge Holder Length: 233 mm / 9.2 in
- Maximum Thrust: 5 kN (5 mm/s)
- Voltage: 18 V
- Battery Capacity: 2.0 Ah
- Battery Charge Time: 65 min (100%)
- Battery Type: Li-ion
- Handle Material: Reinforced Nylon
- Cartridge Holder Material: Steel
- Cartridge Capacity: 1500 mL (52.8 oz)
- Cartridge Ratio: 1:1
- Viscosity: Medium
- Standard Color: Black/Red
- Customized versions on demand

DIMENSIONS

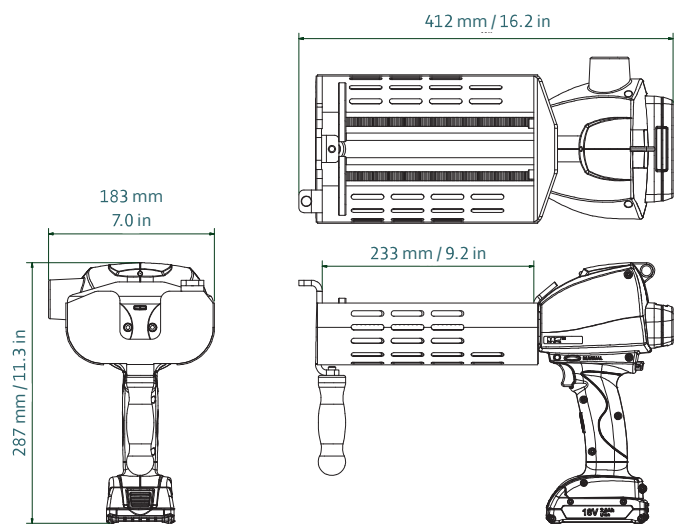

Part number	Article number	Packaging
DB2K 1500-01-500-01	152616	1 per Box
DB2K 1500-01-500-1US	152617 (US)	1 per Box

MATCHING MIXPAC™ SIDE-BY-SIDE CARTRIDGES

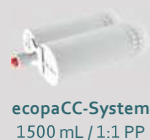

COMPATIBLE CARTRIDGES



1:1	mm	inch
l	215.0	8.46
a	Ø 79.0	Ø 3.11
c	160.0	6.3

CONVERSION KITS

–

MATCHING ACCESSORIES

Batteries and chargers on pages 90.