

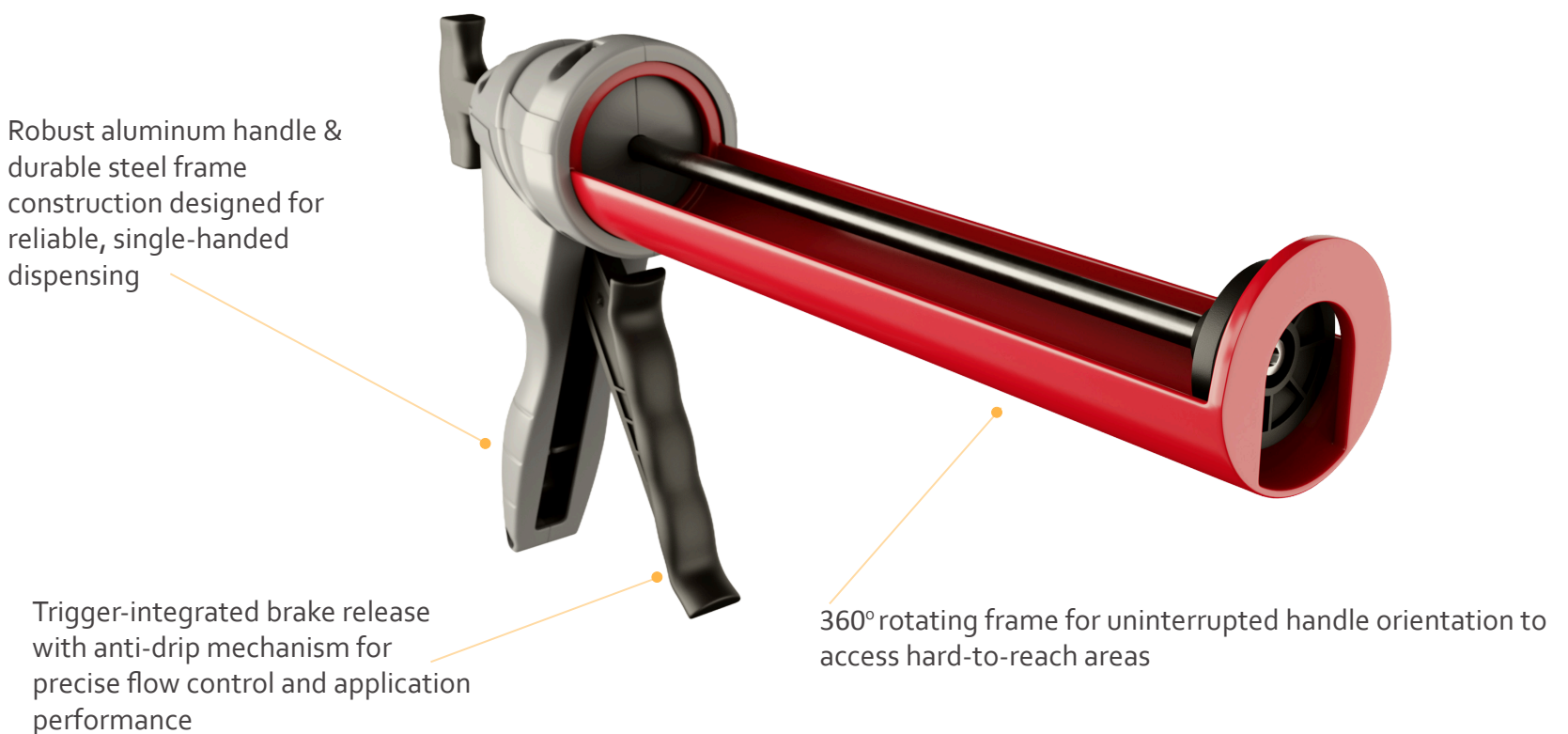

H40+

310mL CARTRIDGE DISPENSER

The new MK™ H40+ is the first of a new generation of MK 1-component, manual dispensers that boast a new and technologically-advanced design.



Part number:	Article number:	Packaging
DM1K 310-CA-R18-602	184014	1 per box
DM1K 310-CA-R18-601	184013	8 per box

Product by range

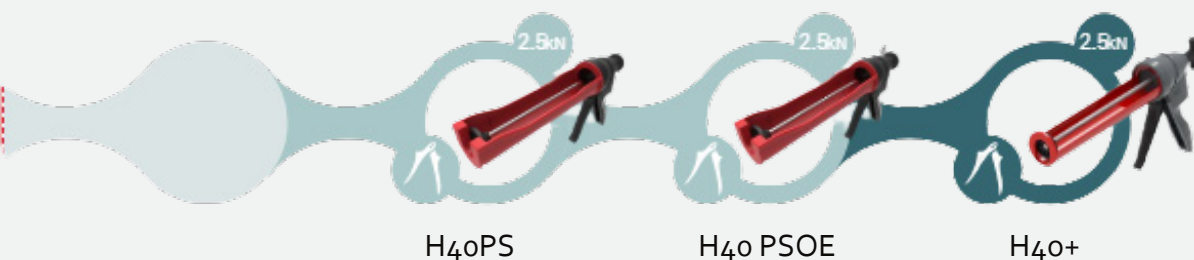



Dimensions

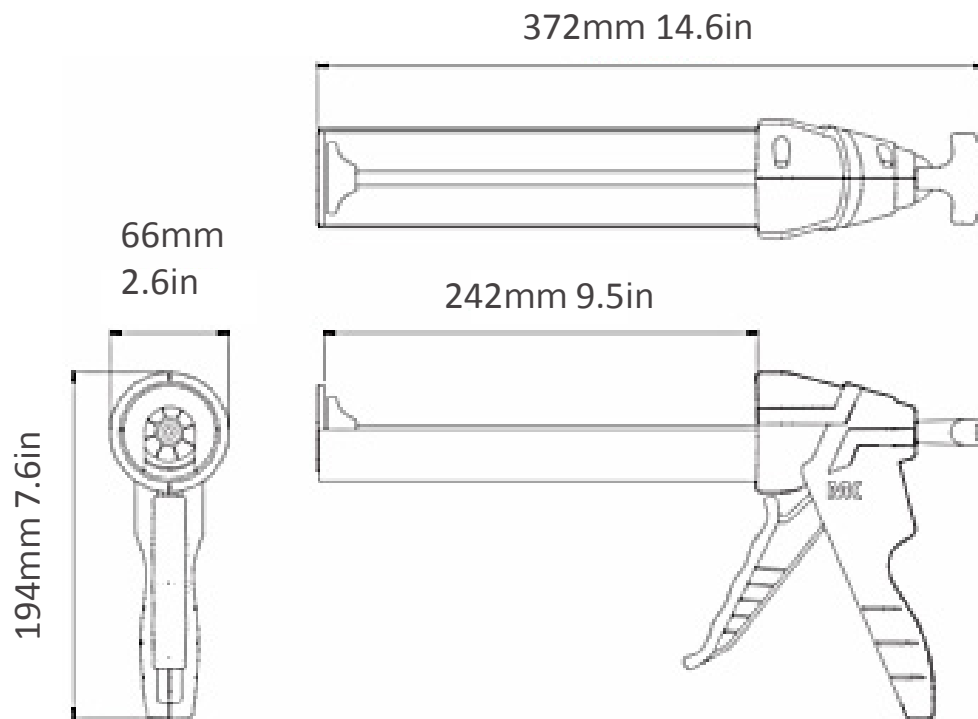

Specifications

- Lightweight: 880g unboxed
- Frame Length: 242mm / 9.5in
- Maximum Thrust: 3kN
- Handle Material: Aluminium
- Frame Material: Steel
- Cartridge Capacity: 310mL
- Standard Color: Grey/Red
- Mechanical Advantage: 18:1

Matching MIXPAC™ cartridges



Peeler Cartridge
310mL

Compatible cartridges



Plastic Cartridge
310mL HPOE/PP/PA

	mm	inch
l	216.0	8.5
a	50	1.8

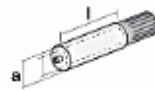

Plastic Cartridge
150mL 1:1, 2:1, 10:1 PP

	mm	inch
l	117	4.6
a	50.0	1.9

Applications



Bonding



Sealing

Why Choose the H40+?

✓ Precision Dispensing

Advanced drive and brake system delivers smooth, accurate flow—no free play, just perfect control.

✓ Mess-Free Application

Enhanced anti-drip and brake release features keep your workspace clean and eliminate rework.

✓ Confident Control

Trigger-controlled brake offers sharper grip and smoother release for total handling confidence.

✓ Power with Ease

20% more thrust than original means faster application with less effort—perfect for thick materials and cold conditions.

✓ Built to Last

Durable, wear-resistant components ensure long-term, professional-grade performance.

✓ Guaranteed Reliability

Backed by a 2-year warranty for peace of mind and proven quality.



For more information please visit www.coxdispensers.com